

- Timing From Microseconds to Hours
- Astable or Monostable Operation
- Adjustable Duty Cycle
- TTL-Compatible Output Can Sink or Source Up To 200 mA

description/ordering information

These devices are precision timing circuits capable of producing accurate time delays or oscillation. In the time-delay or monostable mode of operation, the timed interval is controlled by a single external resistor and capacitor network. In the astable mode of operation, the frequency and duty cycle can be controlled independently with two external resistors and a single external capacitor.

The threshold and trigger levels normally are two-thirds and one-third, respectively, of V_{CC} . These levels can be altered by use of the control-voltage terminal. When the trigger input falls below the trigger level, the flip-flop is set and the output goes high. If the trigger input is above the trigger level and the threshold input is above the threshold level, the flip-flop is reset and the output is low. The reset (RESET) input can override all other inputs and can be used to initiate a new timing cycle. When RESET goes low, the flip-flop is reset and the output goes low. When the output is low, a low-impedance path is provided between discharge (DISCH) and ground.

The output circuit is capable of sinking or sourcing current up to 200 mA. Operation is specified for supplies of 5 V to 15 V. With a 5-V supply, output levels are compatible with TTL inputs.

NE555 . . . D, P, PS, OR PW PACKAGE
SA555 . . . D OR P PACKAGE
SE555 . . . D, JG, OR P PACKAGE
(TOP VIEW)

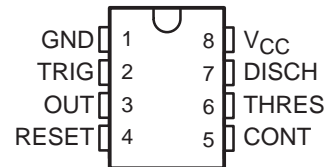

SE555 . . . FK PACKAGE
(TOP VIEW)

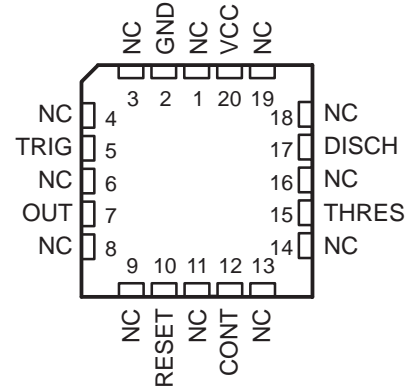

NC – No internal connection



Please be aware that an important notice concerning availability, standard warranty, and use in critical applications of Texas Instruments semiconductor products and disclaimers thereto appears at the end of this data sheet.

PRODUCTION DATA information is current as of publication date. Products conform to specifications per the terms of Texas Instruments standard warranty. Production processing does not necessarily include testing of all parameters.

 **TEXAS
INSTRUMENTS**

POST OFFICE BOX 655303 • DALLAS, TEXAS 75265

Copyright © 2004, Texas Instruments Incorporated
On products compliant to MIL-PRF-38535, all parameters are tested unless otherwise noted. On all other products, production processing does not necessarily include testing of all parameters.

NE555, SA555, SE555 PRECISION TIMERS

SLFS022E – SEPTEMBER 1973 – REVISED MARCH 2004

description/ordering information (continued)

ORDERING INFORMATION

TA	V _{THRES} MAX V _{CC} = 15 V	PACKAGE†		ORDERABLE PART NUMBER	TOP-SIDE MARKING
0°C to 70°C	11.2 V	PDIP (P)	Tube of 50	NE555P	NE555P
		SOIC (D)	Tube of 75	NE555D	NE555
			Reel of 2500	NE555DR	
		SOP (PS)	Reel of 2000	NE555PSR	N555
TSSOP (PW)	Tube of 150	NE555PW	N555		
	Reel of 2000	NE555PWR			
-40°C to 85°C	11.2 V	PDIP (P)	Tube of 50	SA555P	SA555P
		SOIC (D)	Tube of 75	SA555D	SA555
			Reel of 2000	SA555DR	
-55°C to 125°C	10.6 V	PDIP (P)	Tube of 50	SE555P	SE555P
		SOIC (D)	Tube of 75	SE555D	SE555D
			Reel of 2500	SE555DR	
		CDIP (JG)	Tube of 50	SE555JG	SE555JG
LCCC (FK)	Tube of 55	SE555FK	SE555FK		

† Package drawings, standard packing quantities, thermal data, symbolization, and PCB design guidelines are available at www.ti.com/sc/package.

FUNCTION TABLE

RESET	TRIGGER VOLTAGE‡	THRESHOLD VOLTAGE‡	OUTPUT	DISCHARGE SWITCH
Low	Irrelevant	Irrelevant	Low	On
High	<1/3 V _{DD}	Irrelevant	High	Off
High	>1/3 V _{DD}	>2/3 V _{DD}	Low	On
High	>1/3 V _{DD}	<2/3 V _{DD}	As previously established	

‡ Voltage levels shown are nominal.

functional block diagram

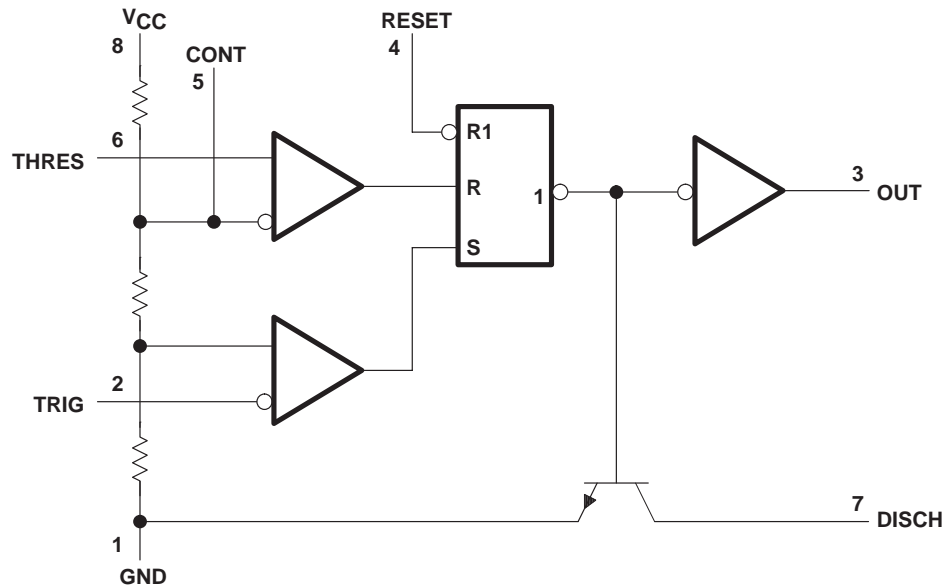

Pin numbers shown are for the D, JG, P, PS, and PW packages.
NOTE A: RESET can override TRIG, which can override THRES.

NE555, SA555, SE555 PRECISION TIMERS

SLFS022E – SEPTEMBER 1973 – REVISED MARCH 2004

absolute maximum ratings over operating free-air temperature range (unless otherwise noted)†

Supply voltage, V_{CC} (see Note 1)	18 V
Input voltage (CONT, RESET, THRES, and TRIG)	V_{CC}
Output current	± 225 mA
Package thermal impedance, θ_{JA} (see Notes 2 and 3):	
D package	97°C/W
P package	85°C/W
PS package	95°C/W
PW package	149°C/W
Package thermal impedance, θ_{JC} (see Notes 4 and 5):	
FK package	5.61°C/W
JG package	14.5°C/W
Operating virtual junction temperature, T_J	150°C
Case temperature for 60 seconds: FK package	260°C
Lead temperature 1,6 mm (1/16 inch) from case for 60 seconds: JG package	300°C
Storage temperature range, T_{stg}	-65°C to 150°C

† Stresses beyond those listed under “absolute maximum ratings” may cause permanent damage to the device. These are stress ratings only, and functional operation of the device at these or any other conditions beyond those indicated under “recommended operating conditions” is not implied. Exposure to absolute-maximum-rated conditions for extended periods may affect device reliability.

- NOTES:
- All voltage values are with respect to GND.
 - Maximum power dissipation is a function of $T_J(\text{max})$, θ_{JA} , and T_A . The maximum allowable power dissipation at any allowable ambient temperature is $P_D = (T_J(\text{max}) - T_A)/\theta_{JA}$. Operating at the absolute maximum T_J of 150°C can affect reliability.
 - The package thermal impedance is calculated in accordance with JESD 51-7.
 - Maximum power dissipation is a function of $T_J(\text{max})$, θ_{JC} , and T_C . The maximum allowable power dissipation at any allowable case temperature is $P_D = (T_J(\text{max}) - T_C)/\theta_{JC}$. Operating at the absolute maximum T_J of 150°C can affect reliability.
 - The package thermal impedance is calculated in accordance with MIL-STD-883.

recommended operating conditions

		MIN	MAX	UNIT
V_{CC} Supply voltage	SA555, NE555	4.5	16	V
	SE555	4.5	18	
V_I Input voltage (CONT, RESET, THRES, and TRIG)			V_{CC}	V
I_O Output current			± 200	mA
T_A Operating free-air temperature	NE555	0	70	°C
	SA555	-40	85	
	SE555	-55	125	



electrical characteristics, $V_{CC} = 5\text{ V to }15\text{ V}$, $T_A = 25^\circ\text{C}$ (unless otherwise noted)

PARAMETER	TEST CONDITIONS		SE555			NE555 SA555			UNIT
			MIN	TYP	MAX	MIN	TYP	MAX	
THRES voltage level	$V_{CC} = 15\text{ V}$		9.4	10	10.6	8.8	10	11.2	V
	$V_{CC} = 5\text{ V}$		2.7	3.3	4	2.4	3.3	4.2	
THRES current (see Note 6)			30	250		30	250	nA	
TRIG voltage level	$V_{CC} = 15\text{ V}$	$T_A = -55^\circ\text{C to }125^\circ\text{C}$	4.8	5	5.2	4.5	5	5.6	V
			3		6				
	$V_{CC} = 5\text{ V}$	$T_A = -55^\circ\text{C to }125^\circ\text{C}$	1.45	1.67	1.9	1.1	1.67	2.2	
					1.9				
TRIG current	TRIG at 0 V		0.5	0.9		0.5	2	μA	
RESET voltage level			0.3	0.7	1	0.3	0.7	1	V
	$T_A = -55^\circ\text{C to }125^\circ\text{C}$				1.1				
RESET current	RESET at V_{CC}		0.1	0.4		0.1	0.4	mA	
	RESET at 0 V		-0.4	-1		-0.4	-1.5		
DISCH switch off-state current			20	100		20	100	nA	
CONT voltage (open circuit)	$V_{CC} = 15\text{ V}$	$T_A = -55^\circ\text{C to }125^\circ\text{C}$	9.6	10	10.4	9	10	11	V
			9.6		10.4				
	$V_{CC} = 5\text{ V}$	$T_A = -55^\circ\text{C to }125^\circ\text{C}$	2.9	3.3	3.8	2.6	3.3	4	
			2.9		3.8				
Low-level output voltage	$V_{CC} = 15\text{ V}$, $I_{OL} = 10\text{ mA}$	$T_A = -55^\circ\text{C to }125^\circ\text{C}$	0.1	0.15		0.1	0.25	V	
					0.2				
	$V_{CC} = 15\text{ V}$, $I_{OL} = 50\text{ mA}$	$T_A = -55^\circ\text{C to }125^\circ\text{C}$	0.4	0.5		0.4	0.75		
					1				
	$V_{CC} = 15\text{ V}$, $I_{OL} = 100\text{ mA}$	$T_A = -55^\circ\text{C to }125^\circ\text{C}$	2	2.2		2	2.5		
					2.7				
	$V_{CC} = 15\text{ V}$, $I_{OL} = 200\text{ mA}$		2.5			2.5			
	$V_{CC} = 5\text{ V}$, $I_{OL} = 3.5\text{ mA}$	$T_A = -55^\circ\text{C to }125^\circ\text{C}$			0.35				
$V_{CC} = 5\text{ V}$, $I_{OL} = 5\text{ mA}$	$T_A = -55^\circ\text{C to }125^\circ\text{C}$	0.1	0.2		0.1	0.35			
				0.8					
High-level output voltage	$V_{CC} = 15\text{ V}$, $I_{OH} = -100\text{ mA}$	$T_A = -55^\circ\text{C to }125^\circ\text{C}$	13	13.3		12.75	13.3	V	
			12						
	$V_{CC} = 15\text{ V}$, $I_{OH} = -200\text{ mA}$		12.5			12.5			
	$V_{CC} = 5\text{ V}$, $I_{OH} = -100\text{ mA}$	$T_A = -55^\circ\text{C to }125^\circ\text{C}$	3	3.3		2.75	3.3		
			2						
Supply current	Output low, No load	$V_{CC} = 15\text{ V}$	10	12		10	15	mA	
		$V_{CC} = 5\text{ V}$	3	5		3	6		
	Output high, No load	$V_{CC} = 15\text{ V}$	9	10		9	13		
		$V_{CC} = 5\text{ V}$	2	4		2	5		

NOTE 6: This parameter influences the maximum value of the timing resistors R_A and R_B in the circuit of Figure 12. For example, when $V_{CC} = 5\text{ V}$, the maximum value is $R = R_A + R_B \approx 3.4\text{ M}\Omega$, and for $V_{CC} = 15\text{ V}$, the maximum value is $10\text{ M}\Omega$.

NE555, SA555, SE555 PRECISION TIMERS

SLFS022E – SEPTEMBER 1973 – REVISED MARCH 2004

operating characteristics, $V_{CC} = 5\text{ V}$ and 15 V

PARAMETER		TEST CONDITION†	SE555			NE555 SA555			UNIT
			MIN	TYP	MAX	MIN	TYP	MAX	
Initial error of timing interval‡	Each timer, monostable§	$T_A = 25^\circ\text{C}$	0.5	1.5*		1	3	%	
	Each timer, astable¶		1.5			2.25			
Temperature coefficient of timing interval	Each timer, monostable§	$T_A = \text{MIN to MAX}$	30	100*		50		ppm/°C	
	Each timer, astable¶		90			150			
Supply-voltage sensitivity of timing interval	Each timer, monostable§	$T_A = 25^\circ\text{C}$	0.05	0.2*		0.1	0.5	%V	
	Each timer, astable¶		0.15			0.3			
Output-pulse rise time		$C_L = 15\text{ pF}$, $T_A = 25^\circ\text{C}$	100	200*		100	300	ns	
Output-pulse fall time		$C_L = 15\text{ pF}$, $T_A = 25^\circ\text{C}$	100	200*		100	300	ns	

* On products compliant to MIL-PRF-38535, this parameter is not production tested.

† For conditions shown as MIN or MAX, use the appropriate value specified under recommended operating conditions.

‡ Timing interval error is defined as the difference between the measured value and the average value of a random sample from each process run.

§ Values specified are for a device in a monostable circuit similar to Figure 9, with the following component values: $R_A = 2\text{ k}\Omega$ to $100\text{ k}\Omega$, $C = 0.1\text{ }\mu\text{F}$.

¶ Values specified are for a device in an astable circuit similar to Figure 12, with the following component values: $R_A = 1\text{ k}\Omega$ to $100\text{ k}\Omega$, $C = 0.1\text{ }\mu\text{F}$.

TYPICAL CHARACTERISTICS†

LOW-LEVEL OUTPUT VOLTAGE
vs
LOW-LEVEL OUTPUT CURRENT

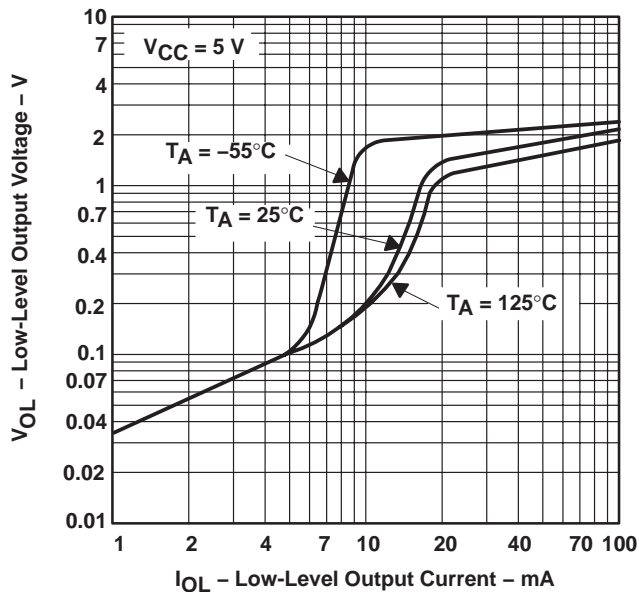

Figure 1

LOW-LEVEL OUTPUT VOLTAGE
vs
LOW-LEVEL OUTPUT CURRENT

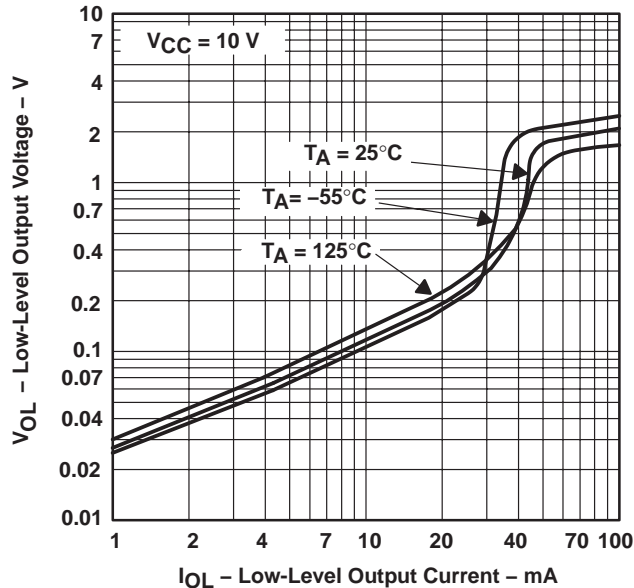

Figure 2

LOW-LEVEL OUTPUT VOLTAGE
vs
LOW-LEVEL OUTPUT CURRENT

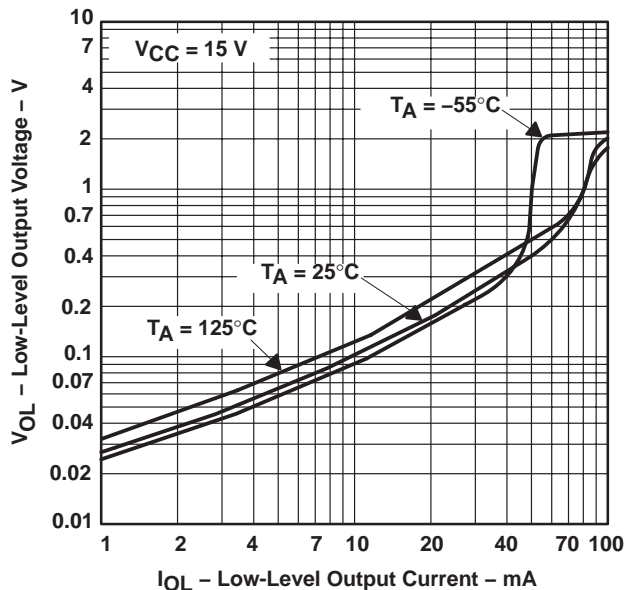

Figure 3

DROP BETWEEN SUPPLY VOLTAGE AND OUTPUT
vs
HIGH-LEVEL OUTPUT CURRENT

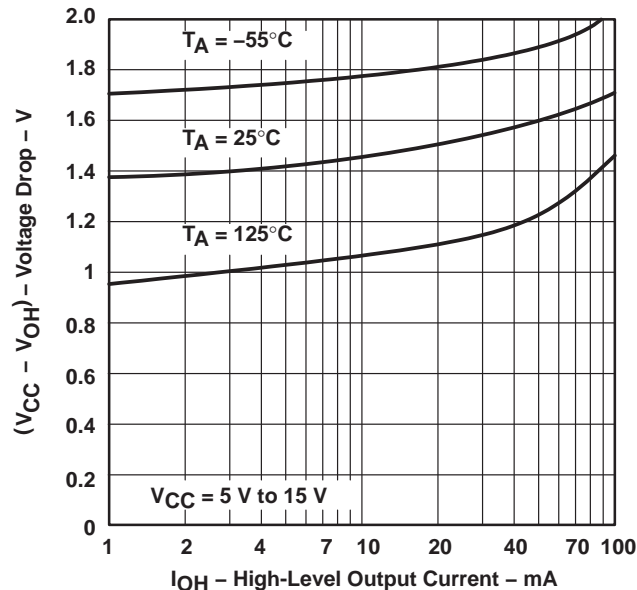
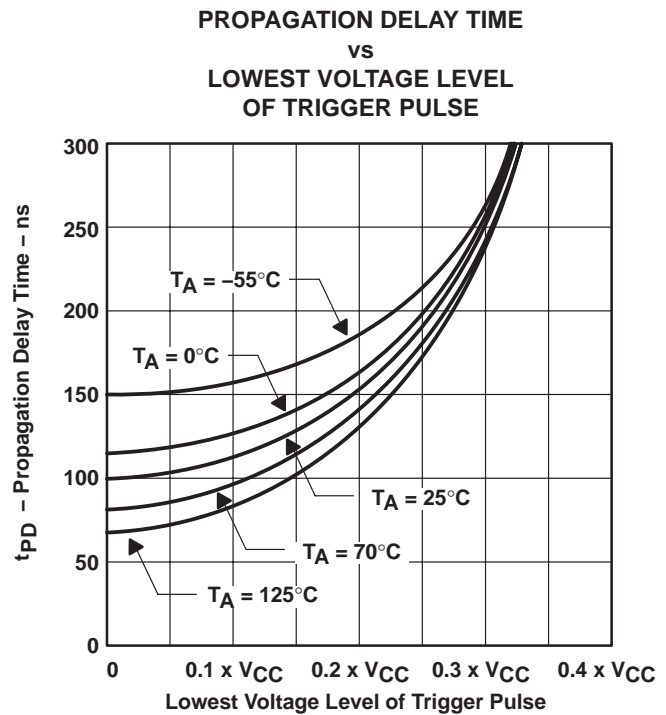
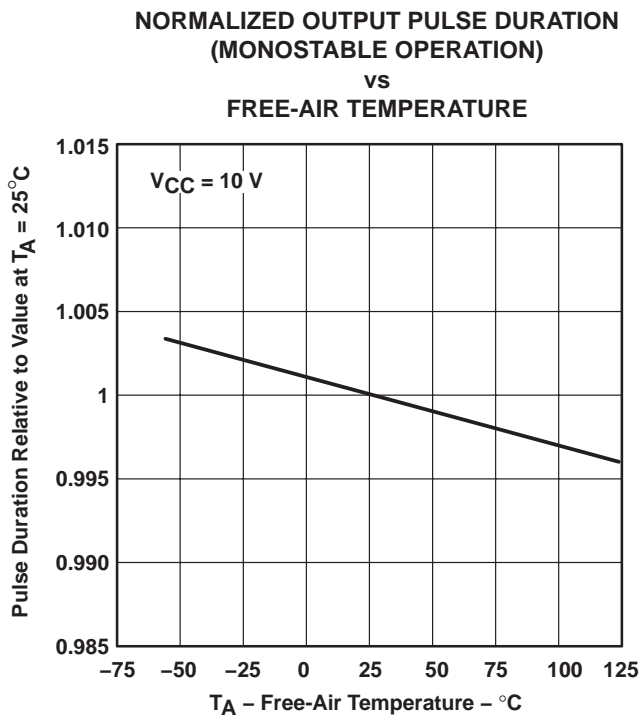
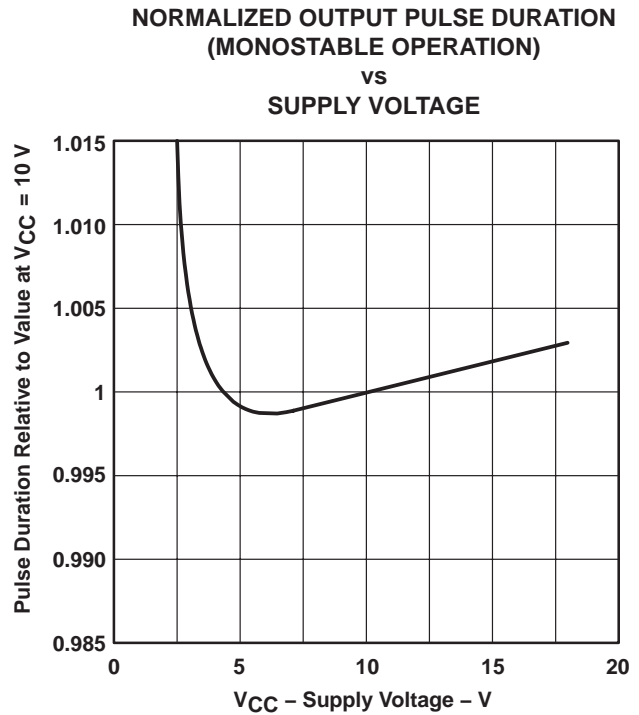
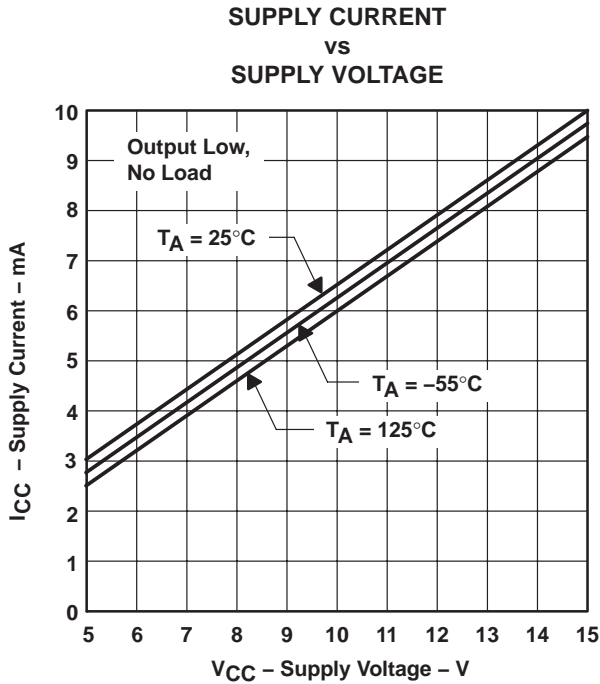

Figure 4

†Data for temperatures below 0°C and above 70°C are applicable for SE555 circuits only.

TYPICAL CHARACTERISTICS†



†Data for temperatures below 0°C and above 70°C are applicable for SE555 series circuits only.

APPLICATION INFORMATION

monostable operation

For monostable operation, any of these timers can be connected as shown in Figure 9. If the output is low, application of a negative-going pulse to the trigger (TRIG) sets the flip-flop (\bar{Q} goes low), drives the output high, and turns off Q1. Capacitor C then is charged through R_A until the voltage across the capacitor reaches the threshold voltage of the threshold (THRES) input. If TRIG has returned to a high level, the output of the threshold comparator resets the flip-flop (\bar{Q} goes high), drives the output low, and discharges C through Q1.

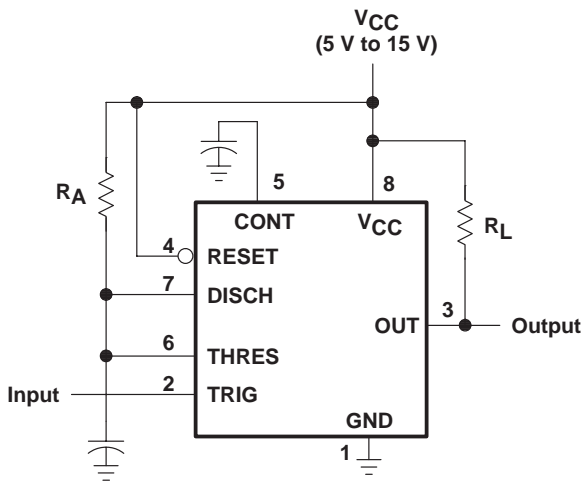

Pin numbers shown are for the D, JG, P, PS, and PW packages.

Figure 9. Circuit for Monostable Operation

Monostable operation is initiated when TRIG voltage falls below the trigger threshold. Once initiated, the sequence ends only if TRIG is high at the end of the timing interval. Because of the threshold level and saturation voltage of Q1, the output pulse duration is approximately $t_w = 1.1R_A C$. Figure 11 is a plot of the time constant for various values of R_A and C. The threshold levels and charge rates both are directly proportional to the supply voltage, V_{CC} . The timing interval is, therefore, independent of the supply voltage, so long as the supply voltage is constant during the time interval.

Applying a negative-going trigger pulse simultaneously to RESET and TRIG during the timing interval discharges C and reinitiates the cycle, commencing on the positive edge of the reset pulse. The output is held low as long as the reset pulse is low. To prevent false triggering, when RESET is not used, it should be connected to V_{CC} .

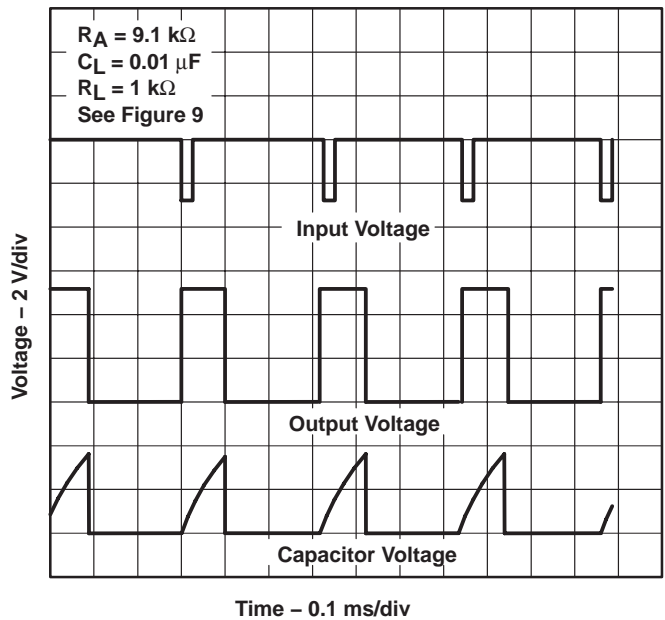

Figure 10. Typical Monostable Waveforms

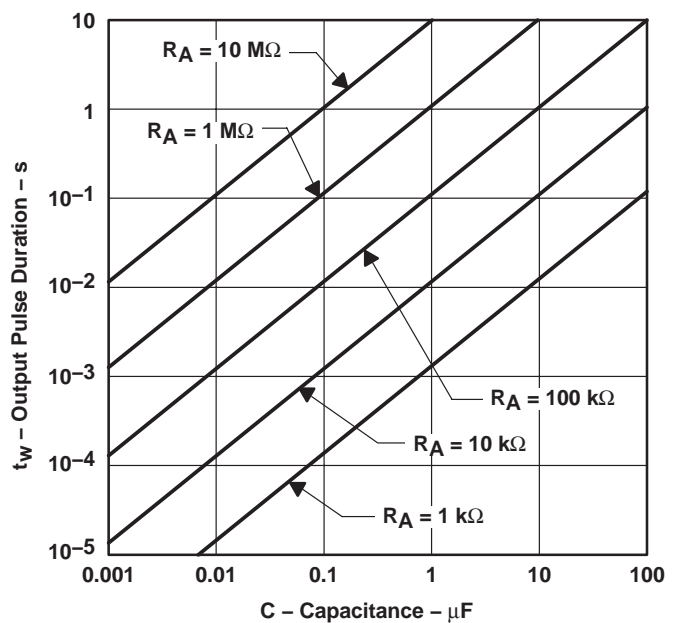

Figure 11. Output Pulse Duration vs Capacitance

APPLICATION INFORMATION

astable operation

As shown in Figure 12, adding a second resistor, R_B , to the circuit of Figure 9 and connecting the trigger input to the threshold input causes the timer to self-trigger and run as a multivibrator. The capacitor C charges through R_A and R_B and then discharges through R_B only. Therefore, the duty cycle is controlled by the values of R_A and R_B .

This astable connection results in capacitor C charging and discharging between the threshold-voltage level ($\approx 0.67 \times V_{CC}$) and the trigger-voltage level ($\approx 0.33 \times V_{CC}$). As in the monostable circuit, charge and discharge times (and, therefore, the frequency and duty cycle) are independent of the supply voltage.

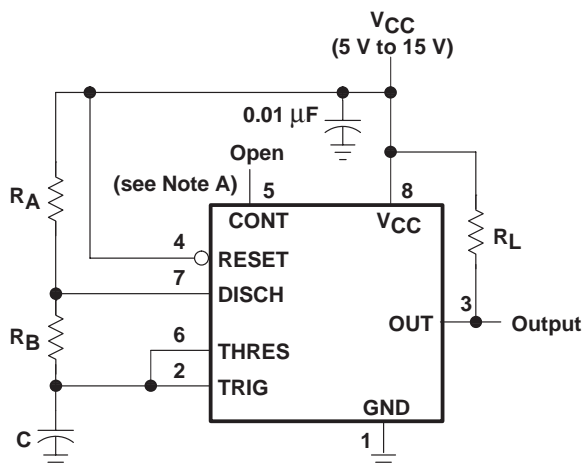

Pin numbers shown are for the D, JG, P, PS, and PW packages.
NOTE A: Decoupling CONT voltage to ground with a capacitor can improve operation. This should be evaluated for individual applications.

Figure 12. Circuit for Astable Operation

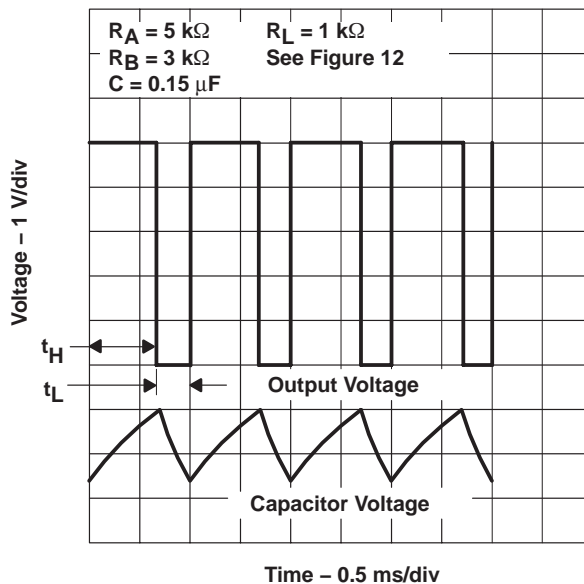

Figure 13. Typical Astable Waveforms

APPLICATION INFORMATION

astable operation (continued)

Figure 13 shows typical waveforms generated during astable operation. The output high-level duration t_H and low-level duration t_L can be calculated as follows:

$$t_H = 0.693 (R_A + R_B) C$$

$$t_L = 0.693 (R_B) C$$

Other useful relationships are shown below.

$$\text{period} = t_H + t_L = 0.693 (R_A + 2R_B) C$$

$$\text{frequency} \approx \frac{1.44}{(R_A + 2R_B) C}$$

$$\text{Output driver duty cycle} = \frac{t_L}{t_H + t_L} = \frac{R_B}{R_A + 2R_B}$$

Output waveform duty cycle

$$= \frac{t_H}{t_H + t_L} = 1 - \frac{R_B}{R_A + 2R_B}$$

$$\text{Low-to-high ratio} = \frac{t_L}{t_H} = \frac{R_B}{R_A + R_B}$$

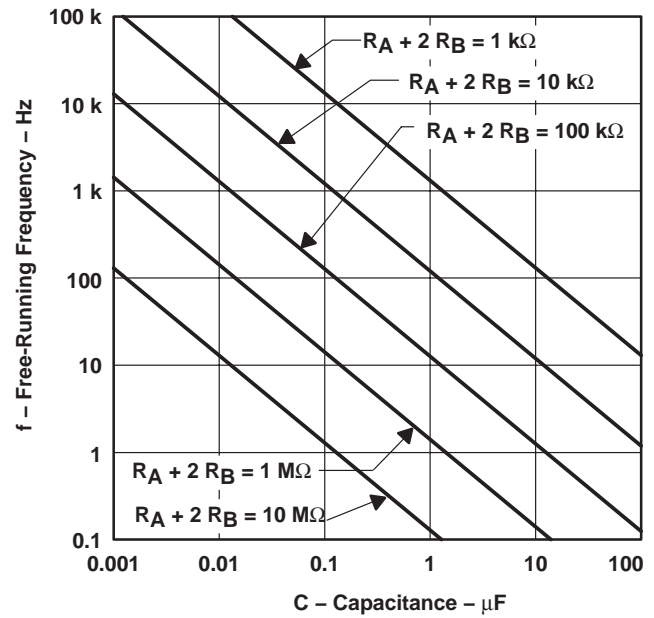
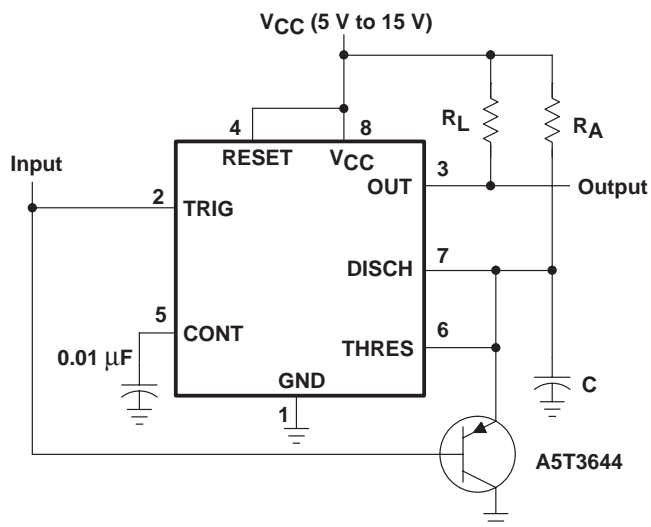

Figure 14. Free-Running Frequency

APPLICATION INFORMATION

missing-pulse detector

The circuit shown in Figure 15 can be used to detect a missing pulse or abnormally long spacing between consecutive pulses in a train of pulses. The timing interval of the monostable circuit is retriggered continuously by the input pulse train as long as the pulse spacing is less than the timing interval. A longer pulse spacing, missing pulse, or terminated pulse train permits the timing interval to be completed, thereby generating an output pulse as shown in Figure 16.



Pin numbers shown are shown for the D, JG, P, PS, and PW packages.

Figure 15. Circuit for Missing-Pulse Detector

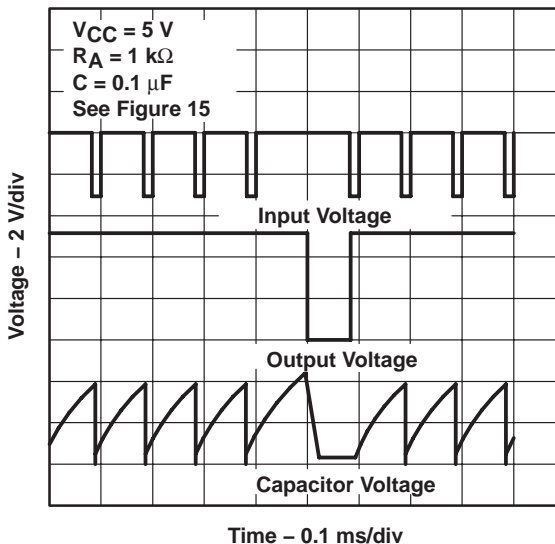

Figure 16. Completed-Timing Waveforms for Missing-Pulse Detector

APPLICATION INFORMATION

frequency divider

By adjusting the length of the timing cycle, the basic circuit of Figure 9 can be made to operate as a frequency divider. Figure 17 shows a divide-by-three circuit that makes use of the fact that retriggering cannot occur during the timing cycle.

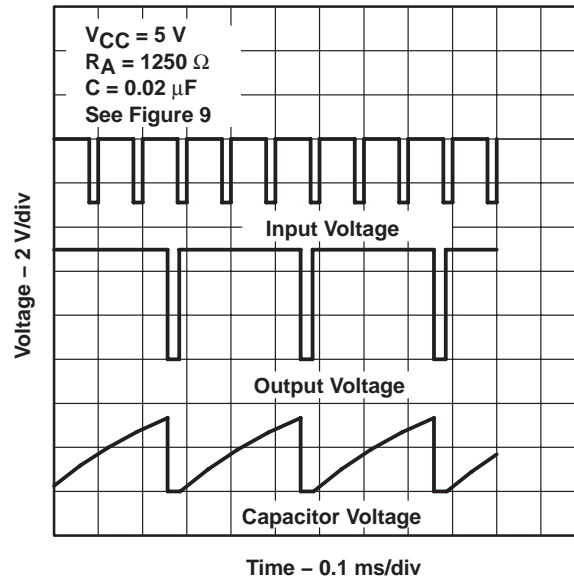
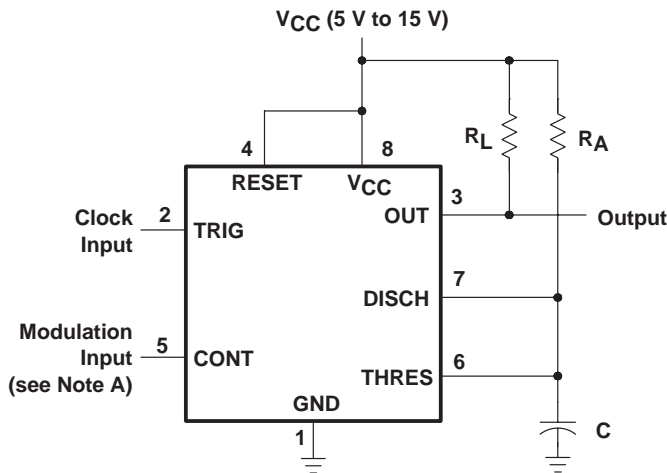

Figure 17. Divide-by-Three Circuit Waveforms

pulse-width modulation

The operation of the timer can be modified by modulating the internal threshold and trigger voltages, which is accomplished by applying an external voltage (or current) to CONT. Figure 18 shows a circuit for pulse-width modulation. A continuous input pulse train triggers the monostable circuit, and a control signal modulates the threshold voltage. Figure 19 shows the resulting output pulse-width modulation. While a sine-wave modulation signal is shown, any wave shape could be used.

APPLICATION INFORMATION



Pin numbers shown are for the D, JG, P, PS, and PW packages.
NOTE A: The modulating signal can be direct or capacitively coupled to CONT. For direct coupling, the effects of modulation source voltage and impedance on the bias of the timer should be considered.

Figure 18. Circuit for Pulse-Width Modulation

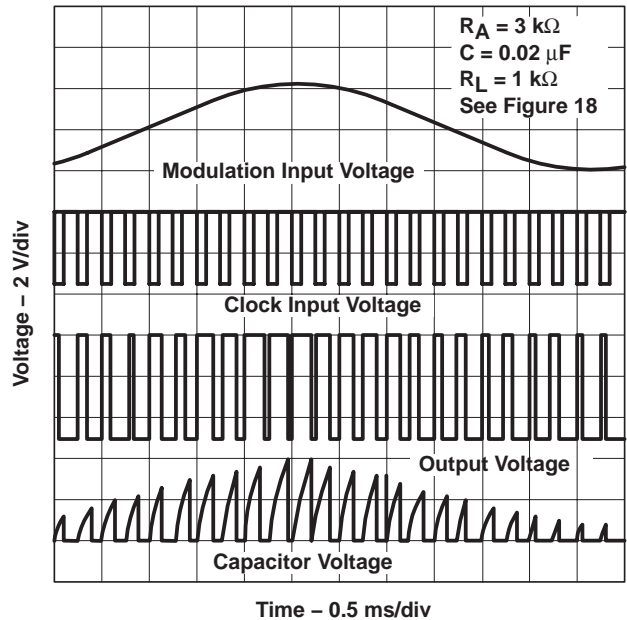
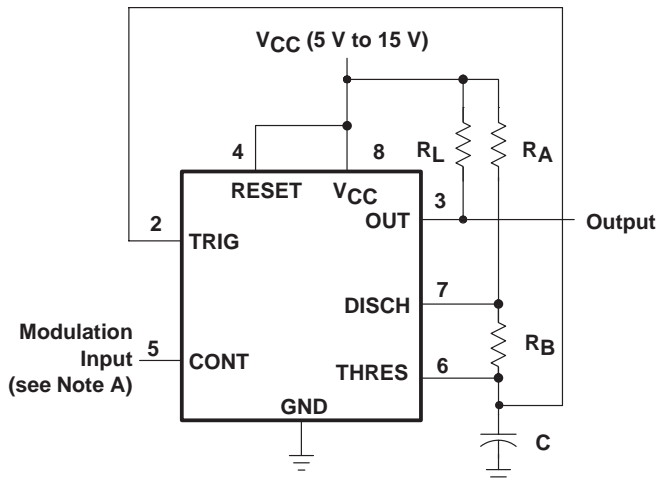

Figure 19. Pulse-Width-Modulation Waveforms

pulse-position modulation

As shown in Figure 20, any of these timers can be used as a pulse-position modulator. This application modulates the threshold voltage and, thereby, the time delay, of a free-running oscillator. Figure 21 shows a triangular-wave modulation signal for such a circuit; however, any wave shape could be used.



Pin numbers shown are for the D, JG, P, PS, and PW packages.
NOTE A: The modulating signal can be direct or capacitively coupled to CONT. For direct coupling, the effects of modulation source voltage and impedance on the bias of the timer should be considered.

Figure 20. Circuit for Pulse-Position Modulation

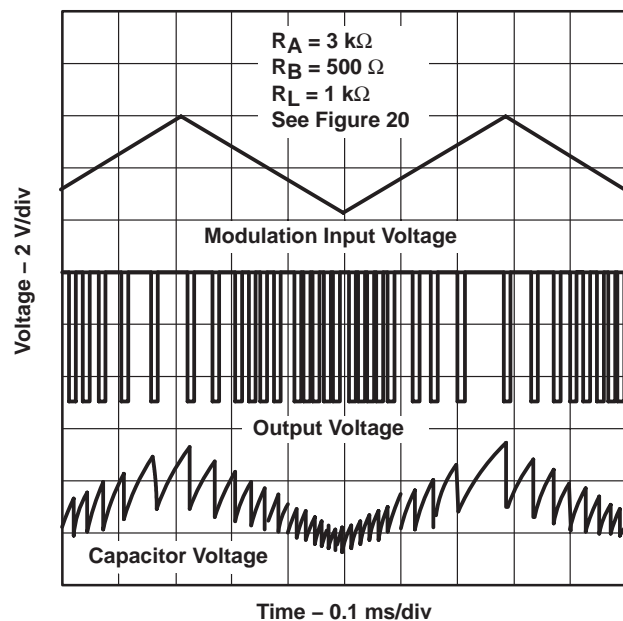
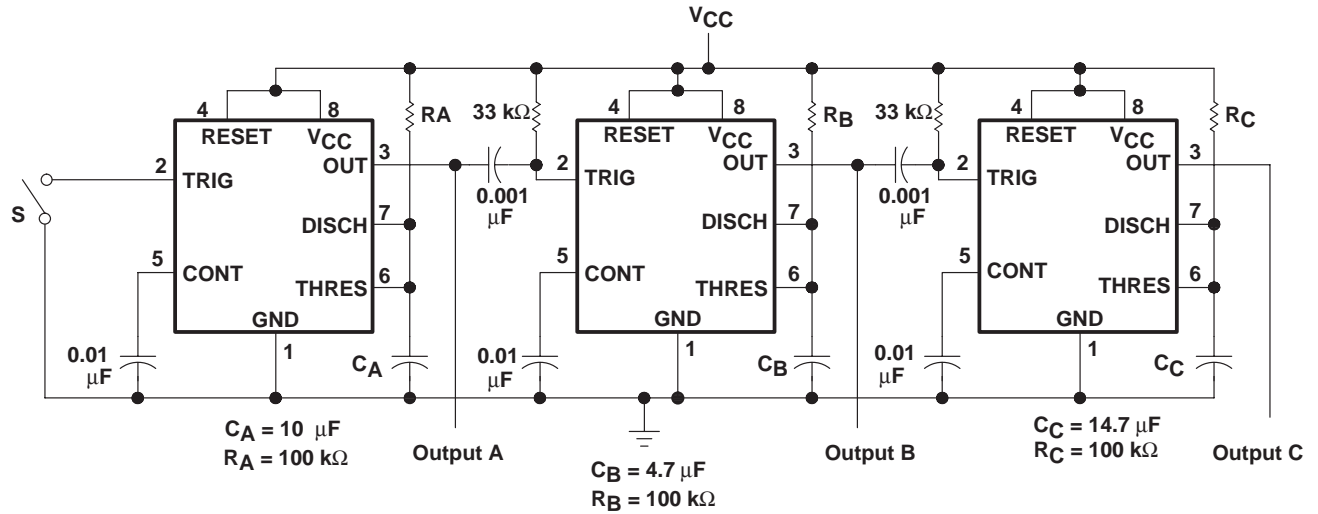

Figure 21. Pulse-Position-Modulation Waveforms

APPLICATION INFORMATION

sequential timer

Many applications, such as computers, require signals for initializing conditions during start-up. Other applications, such as test equipment, require activation of test signals in sequence. These timing circuits can be connected to provide such sequential control. The timers can be used in various combinations of astable or monostable circuit connections, with or without modulation, for extremely flexible waveform control. Figure 22 shows a sequencer circuit with possible applications in many systems, and Figure 23 shows the output waveforms.



Pin numbers shown are for the D, JG, P, PS, and PW packages.

NOTE A: S closes momentarily at $t = 0$.

Figure 22. Sequential Timer Circuit

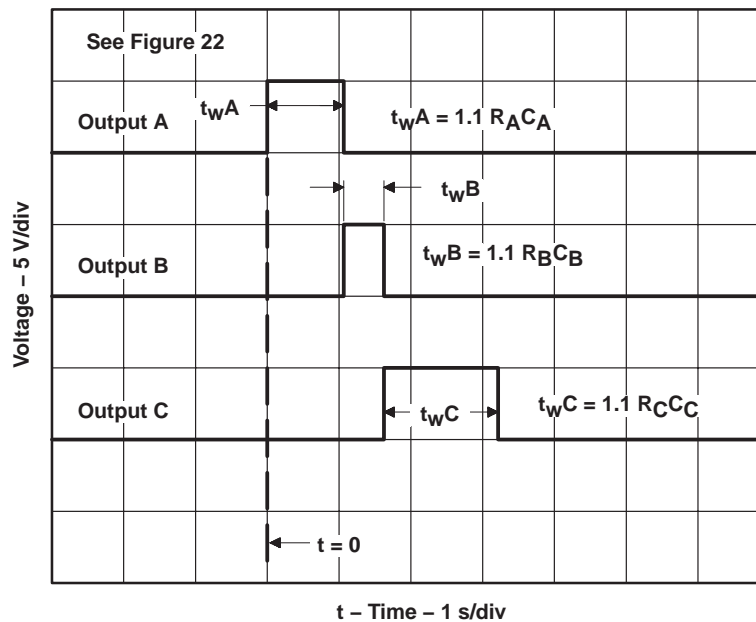

Figure 23. Sequential Timer Waveforms

JG (R-GDIP-T8)

CERAMIC DUAL-IN-LINE



- NOTES: A. All linear dimensions are in inches (millimeters).
 B. This drawing is subject to change without notice.
 C. This package can be hermetically sealed with a ceramic lid using glass frit.
 D. Index point is provided on cap for terminal identification.
 E. Falls within MIL STD 1835 GDIP1-T8

FK (S-CQCC-N**)

LEADLESS CERAMIC CHIP CARRIER

28 TERMINAL SHOWN



- NOTES:
- A. All linear dimensions are in inches (millimeters).
 - B. This drawing is subject to change without notice.
 - C. This package can be hermetically sealed with a metal lid.
 - D. The terminals are gold plated.
 - E. Falls within JEDEC MS-004

P (R-PDIP-T8)

PLASTIC DUAL-IN-LINE

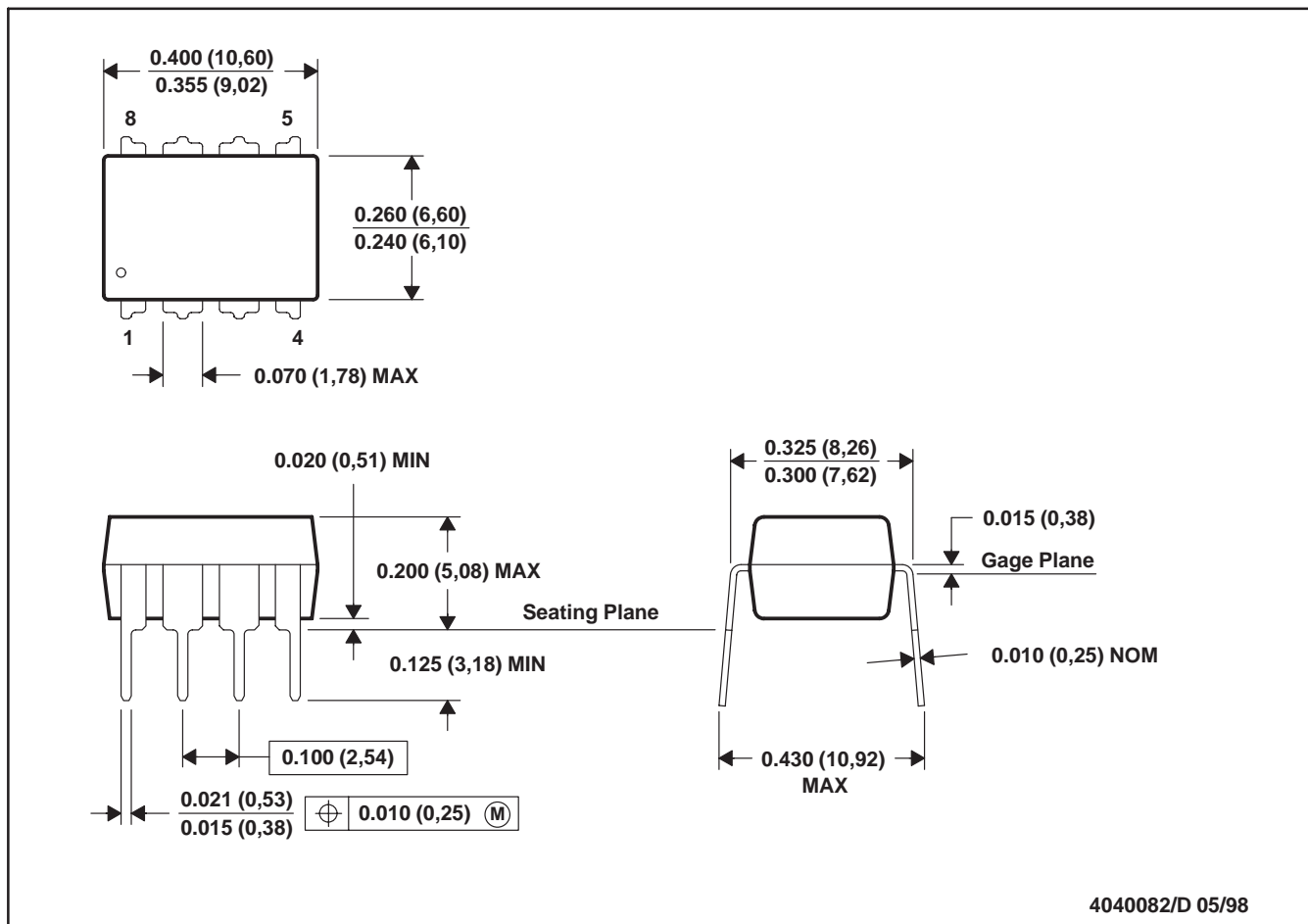

- NOTES: A. All linear dimensions are in inches (millimeters).
 B. This drawing is subject to change without notice.
 C. Falls within JEDEC MS-001

For the latest package information, go to http://www.ti.com/sc/docs/package/pkg_info.htm

N (R-PDIP-T**)

PLASTIC DUAL-IN-LINE PACKAGE

16 PINS SHOWN



- NOTES:
- A. All linear dimensions are in inches (millimeters).
 - B. This drawing is subject to change without notice.
 - Δ Falls within JEDEC MS-001, except 18 and 20 pin minimum body length (Dim A).
 - Δ The 20 pin end lead shoulder width is a vendor option, either half or full width.

N (R-PDIP-T)**

PLASTIC DUAL-IN-LINE PACKAGE

24 PIN SHOWN



- NOTES: A. All linear dimensions are in inches (millimeters).
 B. This drawing is subject to change without notice.
 C. Falls within JEDEC MS-011
 D. Falls within JEDEC MS-015 (32 pin only)

D (R-PDSO-G**)

PLASTIC SMALL-OUTLINE PACKAGE

8 PINS SHOWN



- NOTES: A. All linear dimensions are in inches (millimeters).
 B. This drawing is subject to change without notice.
 C. Body dimensions do not include mold flash or protrusion, not to exceed 0.006 (0,15).
 D. Falls within JEDEC MS-012

MECHANICAL DATA

PS (R-PDSO-G8)

PLASTIC SMALL-OUTLINE PACKAGE



- NOTES:
- A. All linear dimensions are in millimeters.
 - B. This drawing is subject to change without notice.
 - C. Body dimensions do not include mold flash or protrusion, not to exceed 0,15.

PW (R-PDSO-G**)

PLASTIC SMALL-OUTLINE PACKAGE

14 PINS SHOWN



4040064/F 01/97

- NOTES: A. All linear dimensions are in millimeters.
 B. This drawing is subject to change without notice.
 C. Body dimensions do not include mold flash or protrusion not to exceed 0,15.
 D. Falls within JEDEC MO-153

IMPORTANT NOTICE

Texas Instruments Incorporated and its subsidiaries (TI) reserve the right to make corrections, modifications, enhancements, improvements, and other changes to its products and services at any time and to discontinue any product or service without notice. Customers should obtain the latest relevant information before placing orders and should verify that such information is current and complete. All products are sold subject to TI's terms and conditions of sale supplied at the time of order acknowledgment.

TI warrants performance of its hardware products to the specifications applicable at the time of sale in accordance with TI's standard warranty. Testing and other quality control techniques are used to the extent TI deems necessary to support this warranty. Except where mandated by government requirements, testing of all parameters of each product is not necessarily performed.

TI assumes no liability for applications assistance or customer product design. Customers are responsible for their products and applications using TI components. To minimize the risks associated with customer products and applications, customers should provide adequate design and operating safeguards.

TI does not warrant or represent that any license, either express or implied, is granted under any TI patent right, copyright, mask work right, or other TI intellectual property right relating to any combination, machine, or process in which TI products or services are used. Information published by TI regarding third-party products or services does not constitute a license from TI to use such products or services or a warranty or endorsement thereof. Use of such information may require a license from a third party under the patents or other intellectual property of the third party, or a license from TI under the patents or other intellectual property of TI.

Reproduction of information in TI data books or data sheets is permissible only if reproduction is without alteration and is accompanied by all associated warranties, conditions, limitations, and notices. Reproduction of this information with alteration is an unfair and deceptive business practice. TI is not responsible or liable for such altered documentation.

Resale of TI products or services with statements different from or beyond the parameters stated by TI for that product or service voids all express and any implied warranties for the associated TI product or service and is an unfair and deceptive business practice. TI is not responsible or liable for any such statements.

Following are URLs where you can obtain information on other Texas Instruments products and application solutions:

Products		Applications	
Amplifiers	amplifier.ti.com	Audio	www.ti.com/audio
Data Converters	dataconverter.ti.com	Automotive	www.ti.com/automotive
DSP	dsp.ti.com	Broadband	www.ti.com/broadband
Interface	interface.ti.com	Digital Control	www.ti.com/digitalcontrol
Logic	logic.ti.com	Military	www.ti.com/military
Power Mgmt	power.ti.com	Optical Networking	www.ti.com/opticalnetwork
Microcontrollers	microcontroller.ti.com	Security	www.ti.com/security
		Telephony	www.ti.com/telephony
		Video & Imaging	www.ti.com/video
		Wireless	www.ti.com/wireless

Mailing Address: Texas Instruments
Post Office Box 655303 Dallas, Texas 75265